



CYF300W

ISM Transceiver Module With +20dBm(100mW) Output Power

(The purpose of this CYF300W spec covers mainly for the hardware and RF parameter info of the module, For software info please refer to CYF2300A chip datasheet.)

1. General Introduction

CYF300W module series' design is based on the CYF2300A chip, It operate at 433/868/915MHz ISM band , The low receive sensitivity (-120dBm) coupled with +20dBm CYF300W output power ensures extended range and improved link performance.

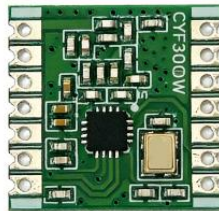

2. Features:

- 140dB maximum link budget.
- Low RX current of 7mA.
- +20 dBm output power CYF300W.
- Programmable bit rate up to 300 kbps@FSK/40 kbps@OOK
- High sensitivity: down to -120dBm .
- FSK, GFSK, and OOK modulation.
- SMD Package (16x16X1.8mm)

3. Application

- Meter Reading
- Wireless data collection
- Automobile security system
- Home automation and security system

4. Pin Definition :

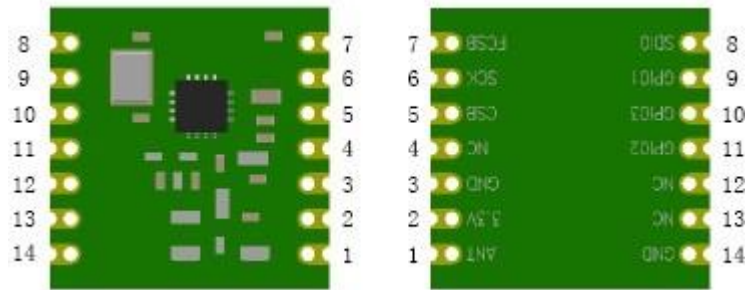

Figure 1. CYF300W Pin Definition

Number	Definition	Type	Function
1	ANT	AI/ AO	RF signal input/output.
2	3.3V(VDD)	PI	Power supply input, 1.8-3.6V.
3	GND	G	Ground.
4	NC		No Connect.
5	CSB	I	SPI Chip select input, active low.
6	SCK	I	SPI Clock input.
7	FCSB	I	SPI FIFO select input, active low.
8	SDIO	I/O	SPI Data input and output.
9	GPIO1	I/O	General Purpose Digital I/O that may be configured through the registers to perform various functions
10	GPIO3		
11	GPIO2		
12	NC		No Connect.
13	NC		No Connect.
14	GND	G	Ground.



5. Electrical Parameter

Maximum

Parameter	Min	Max	Unit
Positive Power Supply	-0.3	+3.6	V
Voltage On Digital Control Inputs	-0.3	VDD + 0.3	V
Voltage On Analog Inputs	-0.3	VDD+ 0.3	V
RX Input Power	-	+10	dBm
Storage Temperature	-55	+125	°C
Soldering Temperature(10s)	-	+255	°C
ESD Rating(Human Body Model)	-2	2	KV

Recommended working range

Parameter	Min	Max	Unit
Positive Power Supply	+1.8	+3.6	V
Working Temperature	-40	+85	°C
Supply Voltage Slew Rate	1	-	mV/us

DC Characteristic

Parameter	Conditions	Min	Typ	Max	Unit
TX Working Current	433MHz band, Pout =+13dBm	-	28	35	mA
	868MHz band, Pout =+13dBm	-	30	35	
	915MHz band, Pout =+13dBm	-	30	35	
RX Working Current	433MHz band,	-	7	10	mA
	868MHz band,	-	7.5	10.5	
	915MHz band,	-	7.5	10.5	
Sleep Current	All band	-	-	1	uA



Transmitter AC characteristic

Parameter	Conditions	Min	Typ	Max	Unit
TX Frequency Range Programmable	433 MHz band,	413	-	453	MHz
	868 MHz band,	848	-	888	
	915 MHz band,	895	-	935	
Output Power	433/868/915MHz band	-	+13	+20	dBm
Symbol Rate, FSK Mode	Programmable	0.1	-	300	kbps
Symbol Rate, OOK Mode	Programmable	0.1	-	40	kbps
Frequency Deviation, FSK	Programmable	1	-	200	KHz
Frequency Resolution		-	24.8	-	Hz

Receiver AC characteristic

Parameter	Conditions	Min	Typ	Max	Unit
RX Frequency Range	433 MHz band,	413	-	453	MHz
	868 MHz band,	848	-	888	
	915 MHz band,	895	-	935	
RX Sensitivity OOK Mode SR = 1.2 kbps	433MHz	-	-120	-	dBm
	868MHz	-	-118	-	
	915MHz	-	-118	-	
RX Sensitivity FSK Mode FDEV = 19.2 kHz, SR = 1.2 kbps,SR = 1.2 kbps	433MHz	-	-118	-	dBm
	868MHz	-	-116	-	
	915MHz	-	-116	-	
Receiver Bandwidth		50		500	KHz
Blocking Immunity	+/-1MHz offset	-	52	-	dB
	+/-2MHz offset	-	74	-	
	+/-10MHz offset	-	75	-	
Image Rejection Ratio	IF=280KHz	-	35	-	dB

6. Typical Application

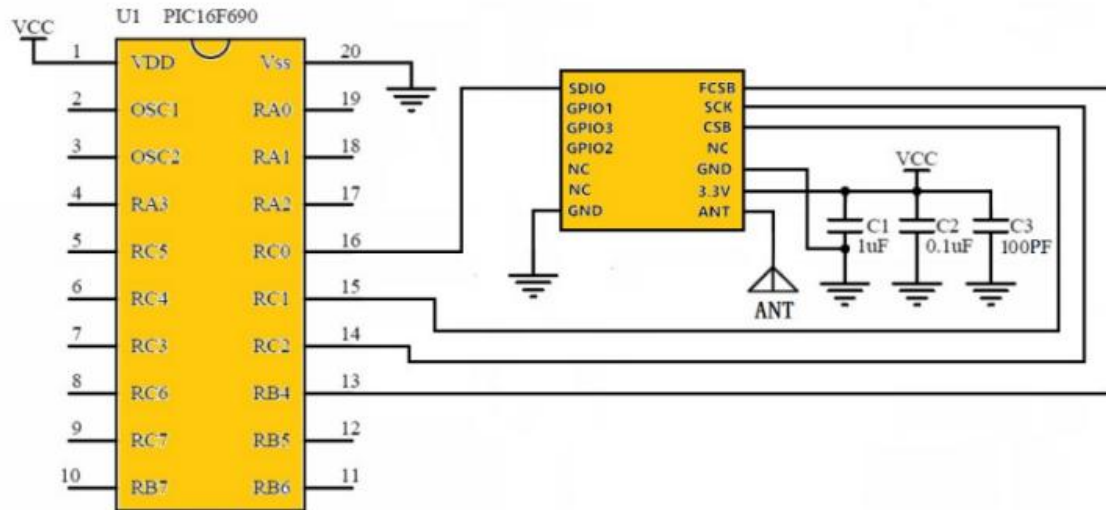

Figure 2. CYF300W Application

(For software info please refer to CYF2300A chip datasheet and demo program)

7. Mechanical Dimension

(All units in mm)

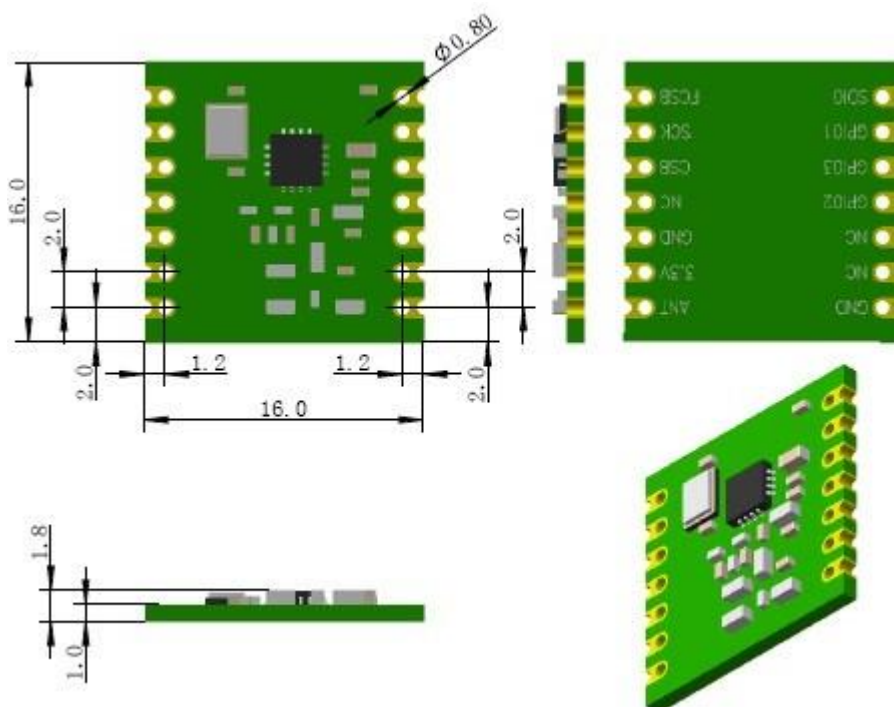

Figure3. CYF300W Mechanical Dimension